

SLIDE & STACK GLASS WALL

GSS 17

System description



Product information

The GSS 17 is a top-hung all-glass slide and stack wall with individually movable panels that are held and guided in a narrow aluminium profile at the top and bottom. The individual glass panels can be easily slid along the entire width of the structure, as well as turned through 90° to form a compact package.

System characteristics

- Top-hung all-glass slide and stack wall
- 3 different bottom tracks (flush with the floor or mounted)
- Glass thickness dependent on the structural requirements: 6 mm, 8 mm and 10 mm single-pane safety glass (ESG)
- Panels can be opened inward or outward
- Construction depth: Ceiling track 53 mm
Bottom track 48 mm
- Panel width up to 900 mm (active panel up to 1000 mm)
- System heights of up to 2700 mm
- Track lengths of up to 6700 mm without a joint
- Height compensation of up to 14 mm (+/- 7 mm)
- Single parking space for up to 8 panels
Double parking space for up to 13 panels
- 3 mm gap between the panels
- Internal stainless steel cable as standard for two-point locking active panel
- Horizontal rollers with milled aluminium bracket
- Concealed fittings made of stainless steel and aluminium
- Available in 16 standard colours and in natural anodised E6/EV1 at no extra charge

Options

- Stainless steel handles, one or both sides
- Lock case, natural and black anodised
- Bottom tracks flush with the floor (type 1 or type 2)
- 90-270° corner solutions
- Transparent H-seal

Performance characteristics



Wind resistance

Class 3 according to EN 12210



Impact resistance

Class 2 according to EN 13049



Panel weight

Up to 65 kg maximum



Continuous function test

Class 2: 10,000 cycles, according to DIN EN 12400



Sound test

according to EN ISO 717-1:
with H-seal = 21 dB; without H-seal = 19 dB



Heat soak test (optional)

EN 14179-1&2:2005

Current test values and certificates are available online at: www.sunparadise.com

- Fixed panel
- Closure possible with or without wall profile
- Active panel latch (type 1 or type 2)
- Satin-finished/etched glass available

What makes the GSS 17 special



1

90° parking space without guide arm

- The individual panels are rotated 90° into the parking space.
- A small plastic opening guides the panels into the parking position without the need for a guide arm.
- The panels can be extended and retracted with ease due to the horizontal rollers.



2

Elegant external appearance

- The glass panes are secured on the outside by four black anodised screws.
- A black anodised profile sits behind the glass surface to create visual harmony.
- A sleek, elegant and continuous external glass surface.



3

Practical stainless steel handle

- The stainless steel handles are available on one or both sides as needed.
- Simply turn gently to activate the steel cable, which in turn actuates the two-point lock; releasing the panel.

Size diagram

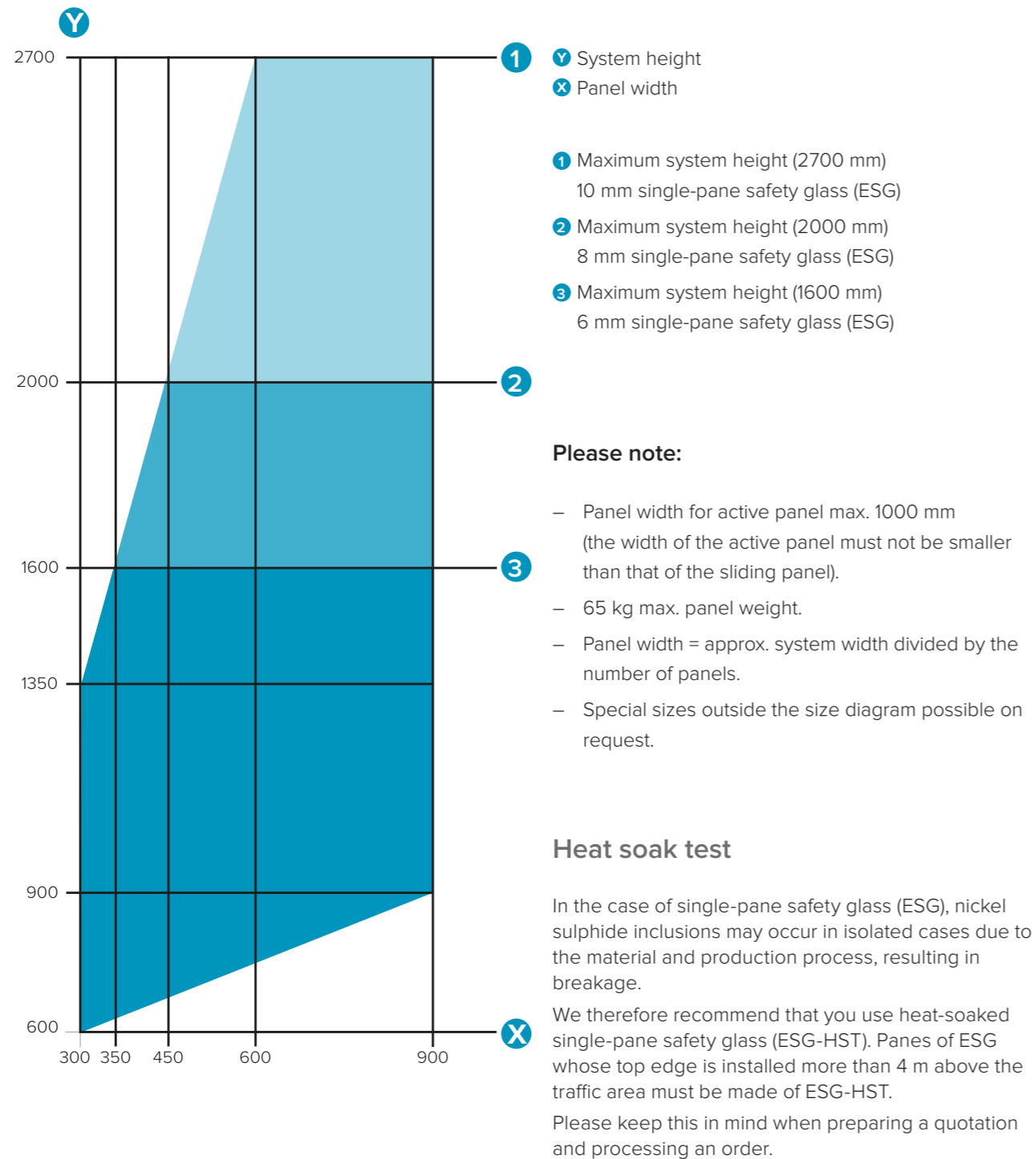

! **Information**

The size diagram does not take into account wind and impact loads. The wind loads/wind pull vary depending on the height, wind zones and building sections. The actual values must be requested from the relevant structural engineer of the building and a calculation must be carried out according to the local conditions and applicable standards.

Parking space diagram

Single parking space

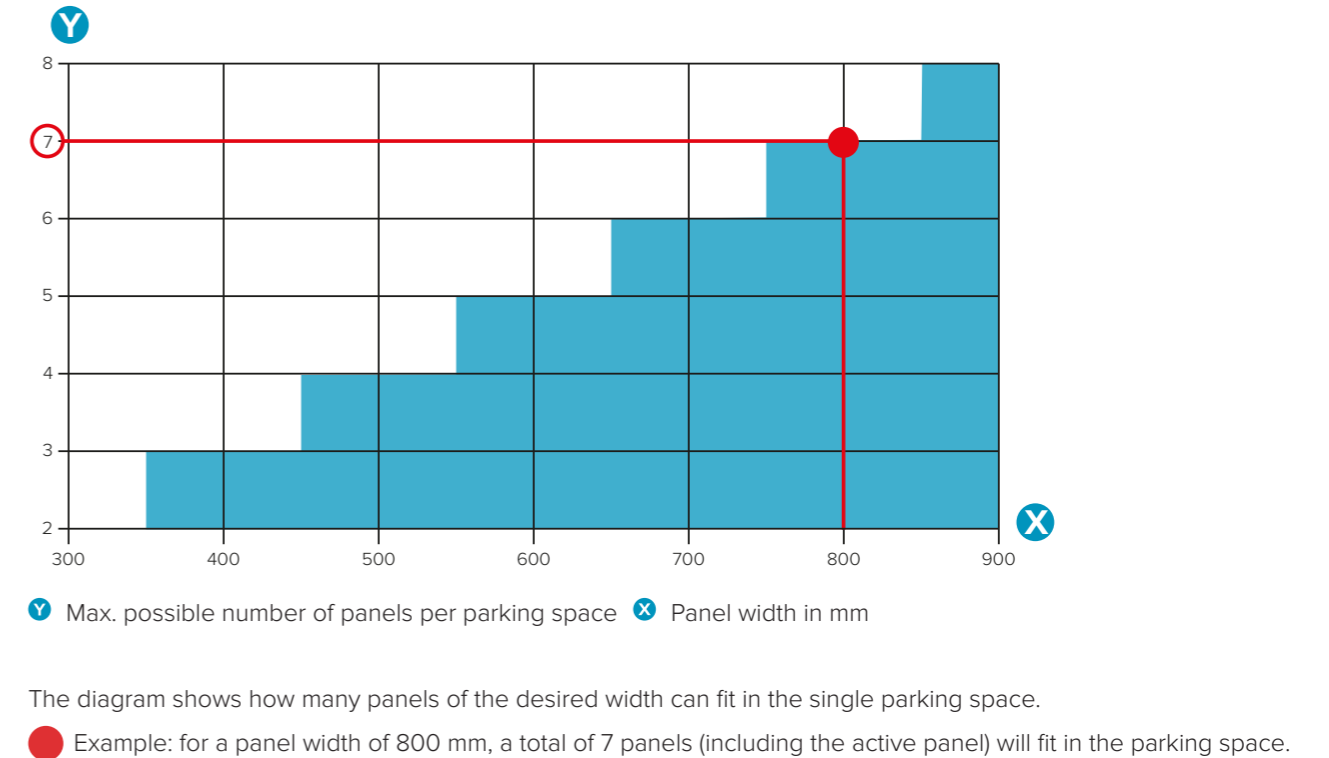

Double parking space

If the maximum number of panels in the single parking space is reached, it is necessary to switch to the double parking space system. In this case, two parking spaces are provided, with space to stack up to 13 panels. To determine the requirements, please refer to the diagram above.

Example:
 For a panel width of 800 mm, 7 panels can be stacked in the first parking space and a further 6 panels in the second (for a maximum total of 13 panels on one parking side).

! **Information on corner systems**

If more than 8 panels are required on one parking side (single or double parking space), the technical feasibility must be approved by Sunparadise before the order is created.

Opening variants

Standard

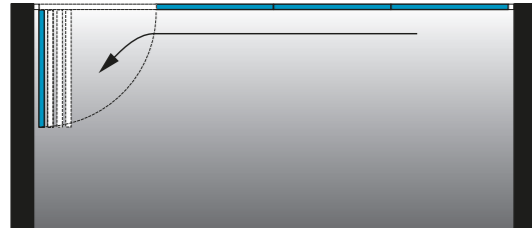

Straight (parking space internal/external)

Optional opening variants

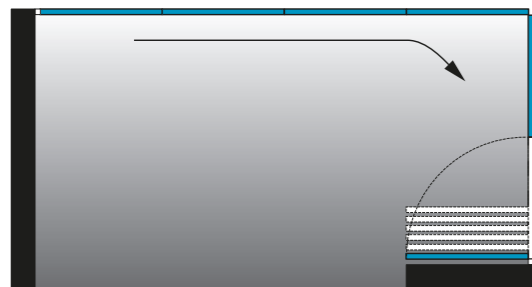

90° around the corner (parking space internal/external)

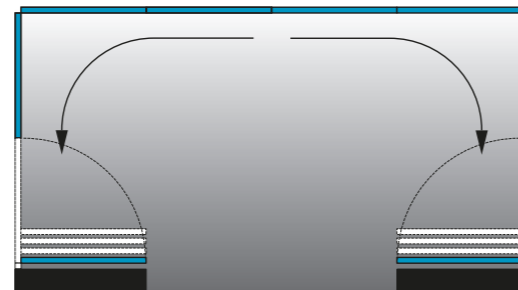

90° centred opening (parking space internal/external)

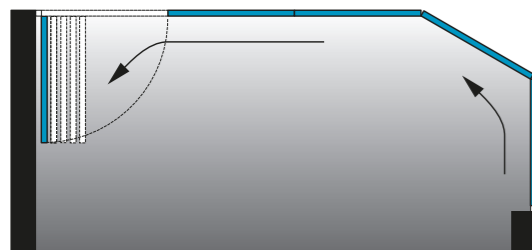

135° around the corner (parking space internal/external)

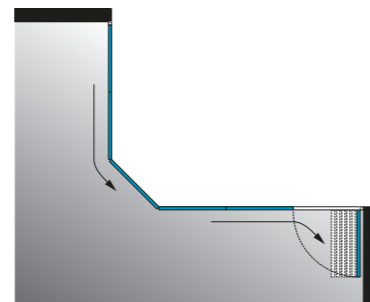

90-270° individual solutions — inside corners (parking space internal/external)

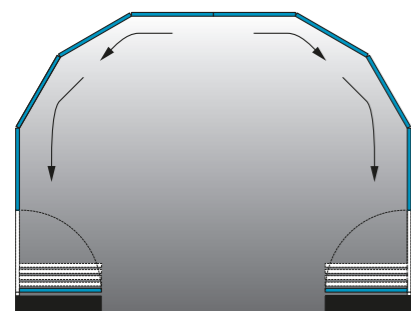

90-270° individual solutions — segmented (parking space internal/external)

! **Information on corner systems**

In corner systems, the system can pivot out up to 450 mm. This dimension depends on the number of panels and their width (roller position). Particular attention must be paid to this if there are railings in front of the system, or if corner posts are present.

The first sliding panel after the active panel must be a 180° panel.

Double parking space

The specially developed double parking space is the ideal solution for large openings such as in the seating area of a restaurant or café, or large balcony fronts or underneath terrace roofs.

With room for up to 13 panels per parking side, it is possible to achieve opening widths of up to 12 metres for systems that open on one side or even up to 24 metres for centred-opening systems.

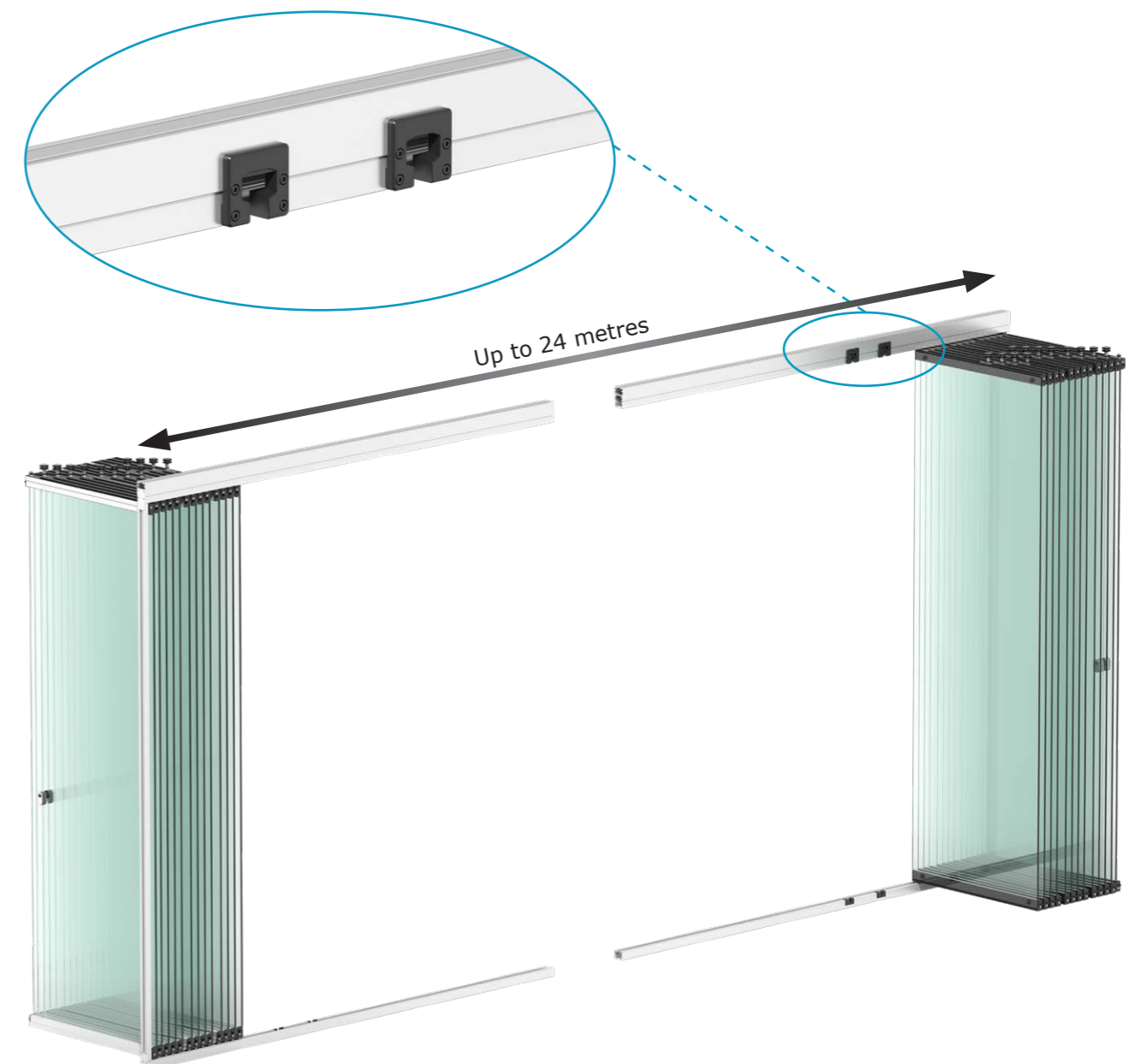

Standard details



Secure guidance

- Special guiding elements ensure optimum pivoting of the panels.
- Securely guided even without an extending arm.
- The guidance system offers protection against incorrect use.

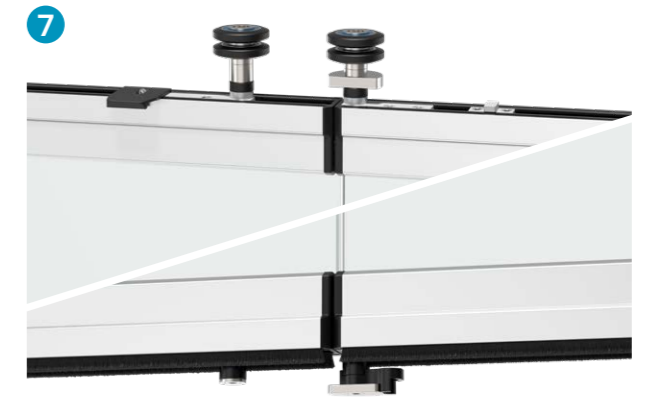

Roller technology

- Horizontal rollers and sliders made of polyoxymethylene thermoplastic.
- Milled aluminium brackets provide stability and visually complete the design.
- Guarantees quiet and smooth operation.

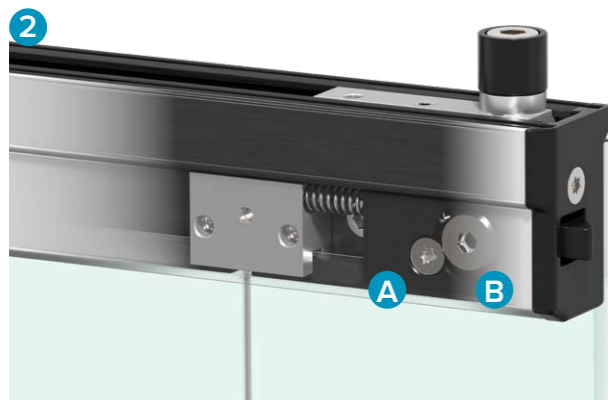

Two-point locking

- Doubly secured panels (locked at the top and bottom).
- Stainless steel wire for easy operation.
- Wire tension can be adjusted at any time with the adjusting (A) and fixing screws (B).



Perfect adjustment

- Individual configuration options on the active panel as well as on individual sliding panels.
- Gap sizes can be optimised in relation to one another.
- For a visually flawless system.



Mounted bottom track

- Only 40 mm high
- Controlled drainage to the exterior.
- Ideal for use on a balcony parapet.



Wall connection

- Seamless connection to the brickwork thanks to double-sided wall profile.
- Elegant and harmonious appearance.



Ceiling track

- Two parts with adjustable height compensation profile.
- Compensation range of 14 mm (+/- 7 mm)
- Precise compensation of construction tolerances.

Extensions and options

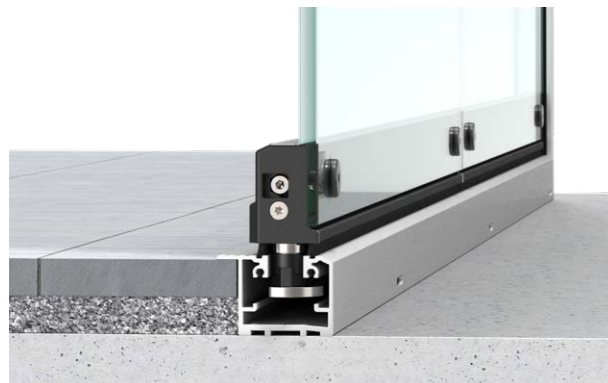

Flush with the floor, type 1 (single-sided)

- Can be sunk into the floor 40 mm on one side.
- Flat and seamless transition on the inside.
- Ideal for the transition from terrace to garden.

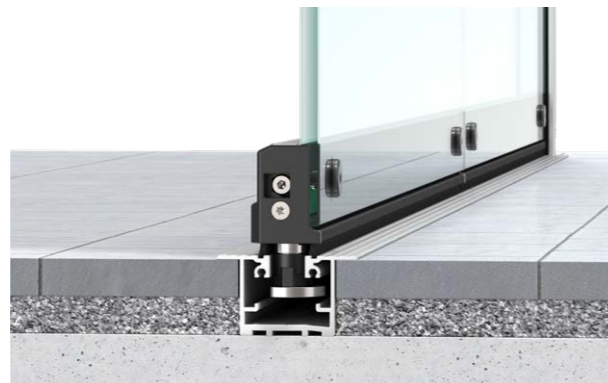

Flush with the floor, type 2 (double-sided)

- Can be sunk into the floor 40 mm on both sides.
- Seamless floor connection thanks to connecting flange on the inside and outside.
- Ideal for wheelchair-accessible designs.



Active panel latch type 1

- Simple latching of the active panel using a small component to hold it in place.
- Protects against accidental and uncontrolled closing (e.g. due to wind gusts).
- Mount available in black, white and grey.



Active panel latch type 2

- Simple latching of the active panel with a wall bracket.
- Protects against accidental and uncontrolled closing (e.g. due to wind gusts).
- Mount available in black, white and grey.



Without wall connection profile

- Suitable for special installation situations where a wall connection cannot be used.



Gap/butt joint seal

- Transparent plastic seal improves resistance to driving rain and wind.
- Sound insulation according to EN ISO 717-1 with seal up to 21 dB.
- Suitable for all glass thicknesses (6, 8 and 10 mm).



Fixed panel

- Fixed panels can be inserted into the design as needed.
- Panel widths from 300 mm to 1000 mm are possible (the panel diagram must be used to determine the possible dimensions).



Handle and lock types

Standard

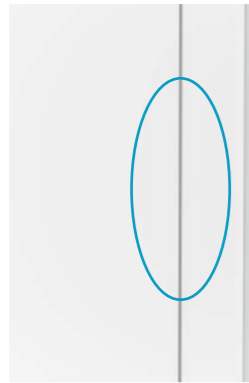

SZ

Type: Cable pull, one-sided
 Operation: Inside
 Colour: Stainless steel

Optional handle types



IDG

Type: Rotary handle
 Operation: Inside
 Colour: Stainless steel



IDB

Type: Rotary handle both sides
 Operation: Inside and outside
 Colour: Stainless steel

Optional lock types



VZ + IDG or IDB

Type: Lock case + rotary handle one or both sides
 Cylinder: Profile cylinder (2 keys)
 Operation: Inside or both sides
 Material: Lock case = brushed aluminium
 Rotary handle = stainless steel
 Colour: Clear or black anodised (lock case)



VH + IDG or IDB

Type: Lock case + rotary handle one or both sides
 Cylinder: Semi-cylinder inside
 Operation: Inside
 Material: Lock case = brushed aluminium
 Rotary handle = stainless steel
 Colour: Clear or black anodised (lock case)



VPZ + IDG or IDB

Type: Lock case + rotary handle one or both sides
 Cylinder: Profile cylinder section (17 mm)
 Operation: Inside or both sides
 Material: Lock case = brushed aluminium
 Rotary handle = stainless steel
 Colour: Clear or black anodised (lock case)

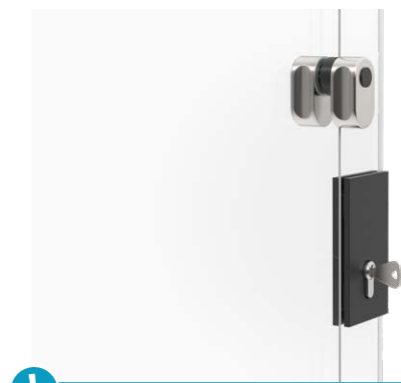

! *Information on lock cases*
 Lock cases (VZ, VH and VPZ) are also available in black anodised.



Balcony glazing

The GSS 17 is also ideally suited for balcony glazing applications in new buildings, as well as in renovation projects or change of use. In recent years there has been a move towards the use of high quality glass systems on balconies to create additional living space for the home. Whilst still classed as outside amenity space, the balconies can be fully enclosed, partially or fully opened up. They are well used, improve lifestyle, provide protection from the elements and form a secure living space for residents.



Advantages

- Protection from the elements, street noise, pollution and intrusion, eg pigeons.
- The entire system can be opened and the panels can be secured against the wall to save space.
- The active panel can be opened like a window for optimum air circulation.
- The ventilation gap enables permanent air exchange which reduces likelihood of condensation on the glass.
- Inward opening panels enable safe and easy cleaning of glazing.

Technical details

- Panel width = from 300 mm
- Panel height = from 600 mm
- Sound insulation = up to 21 dB
- Opening inwards or outwards (recommended: opening inwards for cleaning)



Information on balcony systems

Systems must not be installed outside of balustrades or railings.

FAQs about the GSS 17

Here you will find further information and details as well as answers to frequently asked questions.

For which uses and areas of application is the GSS 17 suited?

In residential applications, the system is suitable for use as full-height balcony glazing. It can also be used on a parapet, or in combination with a Sunparadise terrace roof. The GSS 17 can also be used as a space-saving room divider in the home or office and is the perfect solution for restaurant and hotel terraces.

How many panels can be slid into one parking space?

With the double parking system, up to 13 panels can be accommodated in the same parking space.

Can I re-tighten the steel cable if it loses tension?

The wire rope can be re-tensioned at any time. An adjusting screw and a fixing screw on the top panel profile can be used to make adjustments.

Does the system offer protection from street noise?

Yes, the noise from outside is reduced by up to 21 dB according to the results of tests performed in line with DIN EN ISO 717-1.

In what glass thicknesses is the GSS 17 available?

The panels can be designed with 6 mm, 8 mm or 10 mm single-panel safety glass (ESG). In the case of balcony glazing or properties exposed to wind, it is important to take the effective load values and the applicable standards into consideration. A structural engineer should be consulted to determine the suitable glass thickness.

Can I clean the outside of the panes if I have balcony glazing?

Yes. Both sides of the panels can be accessed from the inside, meaning that the glass can be cleaned easily and safely.



Your partner Sunparadise

Sunparadise has been a reliable partner for over 25 years, offering a broad range and customised products. These allow you to offer your customers the ideal solution for the most varied applications, such as terraces, balconies and facades. Benefit from the advantages of competent advice, personal assistance and mutual cooperation.

Advice and assistance right from the start



Help with project implementation

We offer you assistance ranging from project planning to installation, partnering throughout.



Complete delivery

Our systems are supplied prefabricated in order to guarantee swift and easy installation on site.



Our service does not stop there

Our competent after-sales team will gladly assist you with any queries however large or small.

Certified quality

Accredited certificates prove the quality and expertise behind the systems and services offered by Sunparadise.

- Quality management in accordance with **ISO 9001**
- In-house production control in accordance with **DIN EN 1090**
- Environmental management in accordance with **ISO 14001**

- Certified sound insulation and wind resistance categories
- Burglar resistance in line with **RC3**
- **CE label** in line with EU requirements

EN 1090



Take advantage of the wide range of Sunparadise products and our proven expert consultations. Further information can be found at

sunparadise.com